

DX Series DIN-Rail Mount I/O Modules
DXI8 | DXO8 | DXR6 | DXV4 | DXC4 | DXIO

Specifications

Input Power	9-24Vdc --- 1.5A MAX Class II / Limited Energy Power Supply
Max Relay Current	DXIO: 3.5A per point DXR6: 1A per point
Max Relay Voltage	DXR: 24VAC~ or 24Vdc ---
Transistor Outputs	DXO: Sourcing FETS, 1A
PWM on Transistor Outputs	Channels 1-6, 1kHz
Analog Inputs	DXI: 0-5Vdc / 0-20mA, 12-Bit Jumper Selectable
Analog Outputs	DXV: 0-10V 125mA max / output DXC: 4-20mA
Analog Sensor Power	5Vdc, 500mA max (onboard)
Enclosure Rating	TYPE 12 NEMA
Minimum Cycle Time	1 second
Interface	GrowNET™, MODBUS
Terminal Wire Guage	26 - 16 AWG
Tightening Torque	0.3-0.4 Nm



Contents

Introduction	2		
How "Dry-Contact" Relays Work	3		
Warnings & Precautions	4		
Installation Instructions	5		
DXI8 Terminals	6		
DXR6 Terminals	6		
DXO8 Terminals	7		
DXV4 Terminals	7		
DXC4 Terminals	8		
DXIO Terminals	8		
DIX8, DXIO Inputs (Discrete Sensors)	9		
DIX8, DXIO Inputs (Analog Sensors)	10		
DXO8 Outputs (DC Voltage)	11		
DXO8 Outputs (PWM, AC Infinity Fans)	12		
DXR6 Outputs (Dry Contacts)	13		
DXR6 Outputs (HVAC Control)	14		
DXR6 Outputs (Anden Dehumidifiers)	15		
DXR6 Outputs (Quest Dehumidifiers)	16		
		DXV4 Outputs, 0-10V (Analog Voltage)	17
		DXV4 Outputs, RJ-45 (Gavita)	18
		DXV4 Outputs 0-10V, RJ-12	18
		DXC4 Outputs, 4-20mA (Analog Current)	19
		Connection to GrowControl™ GCX	20
		GrowNET™ Hubs	20
		MODBUS RTU	21
		Serial Speed & Format	21
		Supported Commands	21
		Register Types	21
		MODBUS Holding Registers	22
		MODBUS Coil Registers	23
		Technical Information	23
		Troubleshooting	23
		Maintenance & Service	23
		Storage and Disposal	24
		Warranty	24

KEEP THESE INSTRUCTIONS

This product is intended for commercial use only.

REV 10/24

Introduction

GrowControl DX series digital I/O modules connect Agrowtek's intelligent controllers to devices in your growing environment.

DX modules are intended for:

- Driving electrical contactors and relays (dc coil)
- HVAC, dehumidifier control
- PWM, 4-20mA, or 0-10V control of light dimming and fan speeds
- Discrete and analog sensor inputs
- Miscellaneous control requirements

DX modules are available in a variety of I/O configurations:

I/O Type	DXI8	DXO8	DXR6	DXV4	DXC4	DXIO
Outputs (Transistor)	-	8	-	-	-	2
Outputs (Relay)	-	-	6	-	-	2
Outputs (Analog)	-	-	-	4	4	-
Inputs (Analog/Discrete)	8	-	-	-	-	2

Inputs

DX modules with analog inputs allow connection of various analog or discrete sensors. Inputs are rated 0-5Vdc (or 0-20mA if current jumper is installed for the channel) and are 12 bit (4096 steps.) A 5Vdc 500mA power supply is included on board for powering analog sensors or providing a signaling voltage for discrete or dry-contact sensors.

Typical Discrete Sensors	Typical Analog Sensors
SXL Optical Liquid Detection Sensors	Moisture
Float Switches	Pressure
Door/Window Switches	Temperature
Flow Switches	Other

Relay Outputs

Relay outputs are "dry-contact" type. Dry contact relays operate like a wall switch simply connecting, or disconnecting, a pair of screw terminals. No voltage is provided from a relay output; only passed through the relay from one screw to the other when the contacts are closed. Dry contacts can switch AC or DC power. See the 'about relays' section for more detail.

Analog Outputs

Unlike relay outputs which are discrete (only on or off states,) analog outputs have a variable state and can change within a defined range. Common analog outputs are variable voltage 0-10V (frequently used in light dimming) or variable current 4-20mA (frequently used in variable speed drives.) The control system can modulate the analog output value.

Transistor Outputs

Heavy-duty transistor outputs with transient and flyback protection are designed to connect to DC contactor and relay coils for electrical panel control. Each transistor output is rated at 1A pilot duty (2A max total per unit) and will switch the supplied DC voltage out to the terminals. Heavy duty FET transistors offer robustness and reliability with ultra low heating, and are capable of limited PWM function.

Pulse Width Modulation (PWM)

The first six (6) transistor (FET) outputs may be operated in a 1kHz square-wave PWM (pulse width modulation) duty frequency between 10% and 90%. This allows integration with most lighting dimming controls and fan speed controls.

Duty values below 10% will be output as 0%.

Duty values above 90% will be output as 100%.

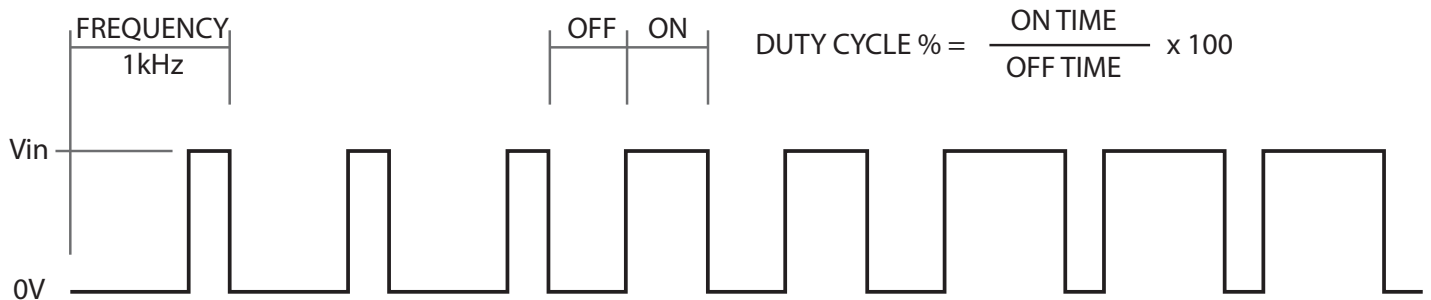

How “Dry-Contact” Relays Work

A relay consists of a mechanical switch and an electro-magnet to turn-on (close) a switch contact. A spring opens the switch when the electromagnet is no longer powered. The microprocessor controls power to the magnet coil to open or close the switch contact as required by the controller program.

Dry-contact relays can be thought of like a wall-switch:

- Each relay “contact” has a pair of screw terminals just like a wall-switch does.
- A wall-switch (or relay contact) does not supply power, it only allows it through.
- Each switch is independent and can operate different circuits or voltages.



A dry-contact relay is exactly the same as a wall switch, however, instead of operating the switch manually with your finger, an electromagnet operates the switch.



Warnings & Precautions

READ & UNDERSTAND ENTIRE MANUAL PRIOR TO INSTALLATION OR OPERATION.

Failure to read, understand and comply with warnings and installation requirements may result in property damage, personal injury or death.

DANGER Electrocutation Hazard

Disconnected all power sources before servicing or wiring. Install all electrical equipment and wiring in accordance with national and local electric codes. For indoor use in dry locations only (0-80% RH non-condensing.) Replace serviceable parts only with those recommended by Agrowtek Inc.

DANGER Risque d'électrocution

Débranchez toutes les sources d'alimentation avant l'entretien ou le câblage. Installez tous les équipements électriques et le câblage conformément aux codes électriques nationaux et locaux. Pour une utilisation en intérieur dans des endroits secs seulement (0-80% RH sans condensation.) Remplacer les pièces réparable seulement avec ceux recommandés par Agrowtek Inc.

THIS PRODUCT IS NOT INTENDED FOR LIFE SAFETY APPLICATIONS.

Do not install in hazardous locations or rely solely on this equipment for control over life safety.

INSTALL IN ACCORDANCE with all national and local plumbing and electrical codes.

Information in this manual is intended for use by individuals possessing adequate backgrounds of electrical and mechanical experience and who comply with all federal, state, and local laws, rules, orders, or regulations related to the installation, service, or repair of electrical, HVAC and related equipment. Any attempt to install, service, or repair equipment may result in personal injury and/or property damage. The manufacturer or seller cannot be responsible for the interpretation of the information contained herein, nor can it assume any liability in connection with its use.

DANGER: ELECTROCUTION HAZARD

Disconnect power before maintenance or service on the system or system components to prevent equipment damage or electrical shock. Use caution when servicing plumbing to drain the system off away from electrical components and connections. Connect the system and components to GFCI fault protected energy sources to reduce risk of electric shock.

INDOOR LOCATIONS ONLY

This system is designed for indoor mounting only and must be protected from weather and direct sunlight.

PREVENT OVER HEATING

Keep air space around the system cool and ventilated to prevent overheating of system components.

WARNING

This product may contain chemicals known to the State of California to cause cancer and birth defects or other reproductive harm.

Installation Instructions

DX series modules are designed for DIN rail mounting in electrical control cabinets and should be enclosed due to the exposed terminal design. If DIN rail is not available, brackets include mounting holes for surface mounting.

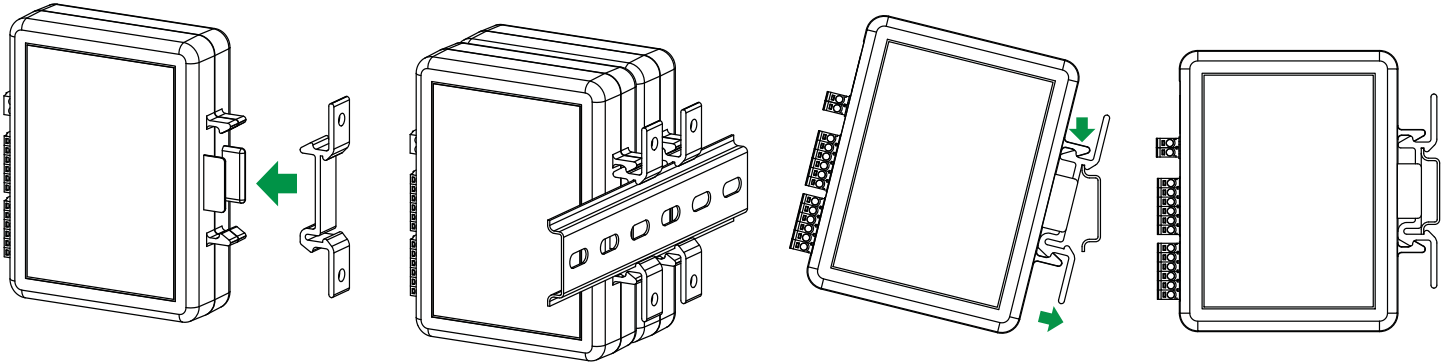

Wiring terminals are “pluggable” blocks and can be removed from the module by pulling the terminal block away from the module face. This is convenient for wiring and for replacing a module in the event of a failure without the need to remove wiring from the terminals.

DXI8 Terminals

DXI8 modules feature eight (8) analog inputs for 0-5V or 0/4-20mA sensors. Inputs can also be used as discrete type. An on-board 5Vdc power supply provides up to 500mA of current to drive sensors and for use in discrete sensing applications.

Power is provided to the module via the RJ-45 GrowNET™ port.

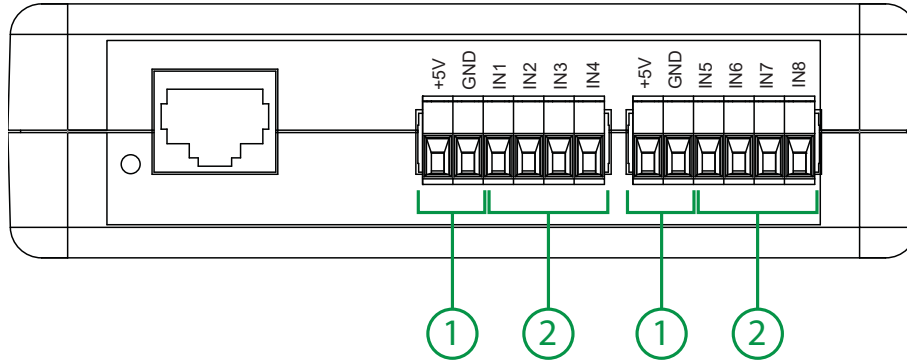

1. 5Vdc Power Supply Common 5Vdc power supply for driving sensors or for discrete sensing. Both pairs of terminals are supplied by a common 500mA switch mode power supply.

2. Inputs 1-8 Sinking inputs measure 0-5Vdc by default. Discrete sensors switch the supplied 5Vdc to an input to trigger it. Inputs may be configured for current sensing (0-20mA) by setting a jumper on the pcb inside of the module.

DXR6 Terminals

DXR6 modules feature six (6) normally open (N.O.) dry contact outputs for operating low-voltage control signals common in HVAC and other control applications. Each contact is capable of 1A at up to 24Vdc/Vac.

Power is provided to the module via the RJ-45 GrowNET™ port.

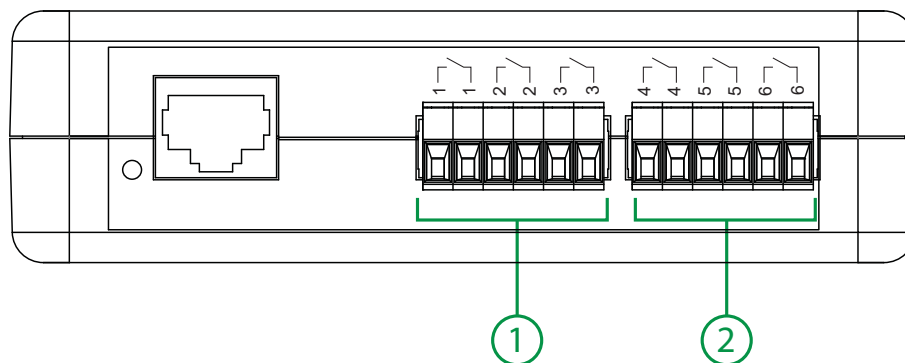

1. Relays 1 - 3 Relay contacts 1 through 3, normally open (form A.)

2. Relays 4 - 6 Relay contacts 4 through 6, normally open (form A.)

DXO8 Terminals

DXO8 modules feature eight (8) FET (transistor) outputs for providing DC power. Each fet is capable of 1A with a maximum device total of 8A. **DC power MUST be supplied to the input terminals to power the outputs.**

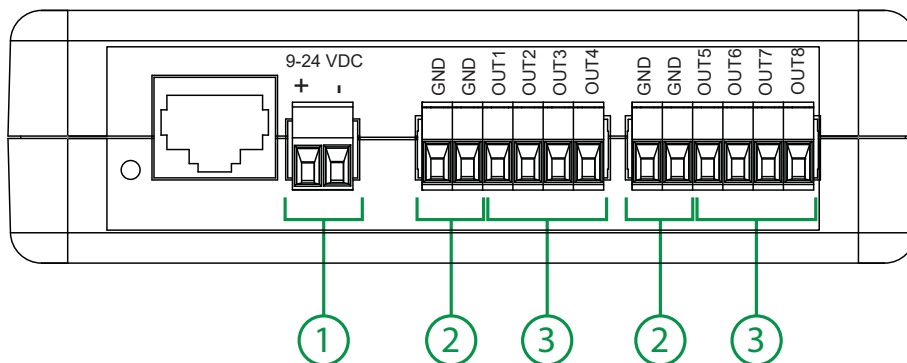

1. **Vin** Power input terminals; 24VDC required to provide power to the output terminals (OUT1 - OUT8).
2. **GND** Common DC ground terminals for connections.
3. **Outputs 1-8** Positive sourcing DC transistor outputs for driving solenoids, relays, contactors, etc. with a DC voltage. The first six (6) of the outputs can be configured for PWM control between 10-90% for motor speed control, light dimming, etc.

DXV4 Terminals

DXV4 modules feature four (4) analog 0-10Vdc outputs for operating ballast dimming signals, variable speed drives, and other devices with a analog voltage control input.

Power is provided to the module via the RJ-45 GrowNET™ port.

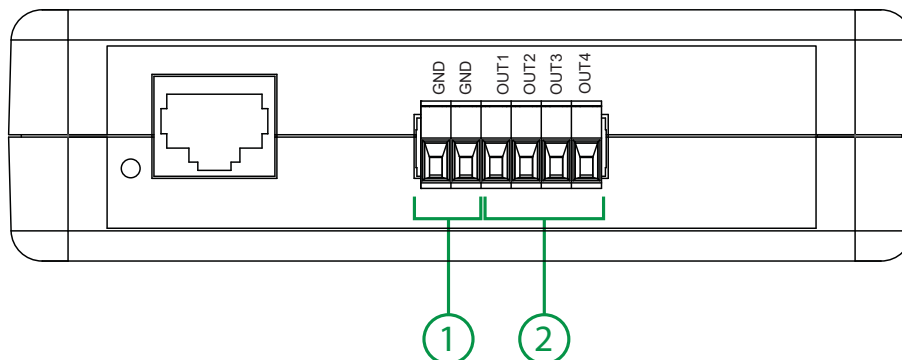

1. **GND** Common DC ground terminals for connections.
2. **Analog Outputs 1-4** Sinking/Sourcing DC outputs for driving lighting dimming controls and other equipment with a 0-10Vdc analog input. Each channel is capable of driving up to 50 light fixtures (125mA max. per channel.)

DXC4 Terminals

DXC4 modules feature four (4) analog 4-20mA outputs for PLC's, variable speed drives, and other devices with a analog current control input. Power is provided to the module via the RJ-45 GrowNET™ port.

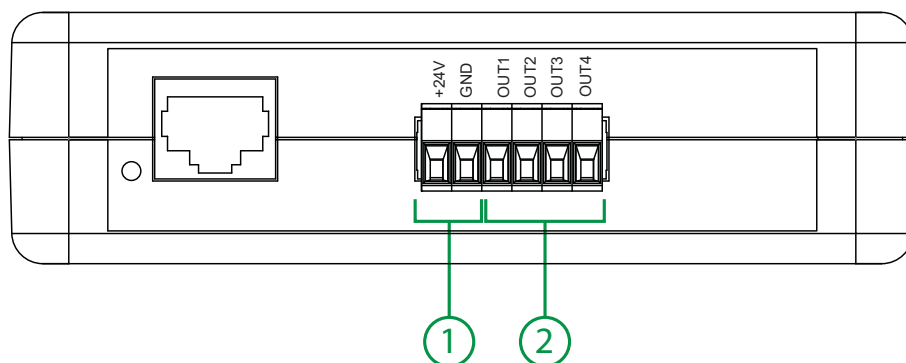

1. **+24V/GND** Common DC ground and +24Vdc power out (500mA max.)
2. **Analog Outputs 1-4** Independent 4-20mA current outputs.

DXIO Terminals

DXIO modules feature a mix of I/O including (2) FET (transistor) DC Outputs, (2) Analog/Discrete Inputs, (2) Form C Dry-Contact Relays **DC power is optional on the DC power input terminals of this module.** *If using the DC outputs it is recommended to provide DC power to the input terminals.*

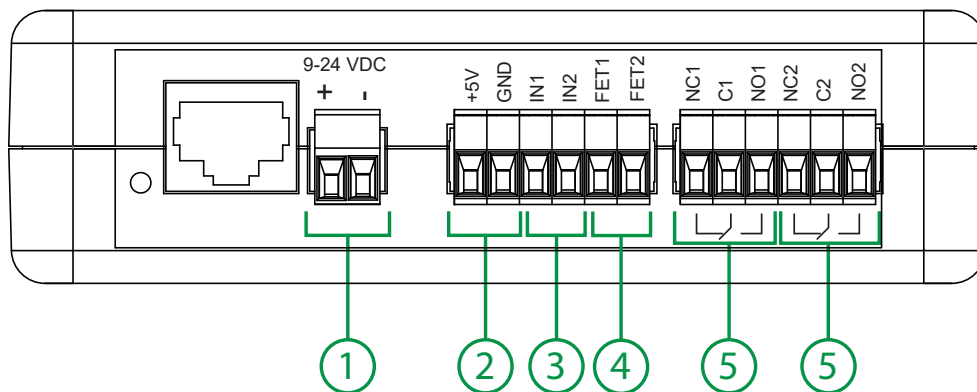

1. **Vin** Vin terminals to provide DC power to the FET outputs.
2. **5Vdc Power Supply** Common 5Vdc power supply for driving sensors or for discrete sensing.
3. **Inputs 1-2** Sinking inputs measure 0-5Vdc by default. Inputs may be configured for current sensing (0-20mA) by setting a jumper on the pcb inside of the module.
4. **Outputs 1-2 (DC transistor)** Positive sourcing DC transistor outputs for driving solenoids, relays, contactors, etc. with a DC voltage. The outputs can be configured for PWM control between 10-90%.
5. **Outputs 3-4 (dry contact relay)** Form C (N.C./N.O.) 5A dry contacts.

DIX8, DXIO Inputs (Discrete Sensors)

Discrete type sensors offer only an indication of “true” or “false” and no information in between. Typical examples include liquid presense detection sensors, manual and proximity switches, door and window switches, etc.

Passive Sensors

Passive sensors are simple, typically mechanical sensors that manipulate a physical switch (dry contact) to close a circuit. Passive sensors do not have any electronics on board and simply pass through the signal voltage when the condition is true. Passive sensors only require two wires; the signal voltage and the sensor output.

Active Sensors

Active sensors have electronics on board and require both a power and ground wire to operate the sensor, plus a third wire to carry the output signal of the sensor.

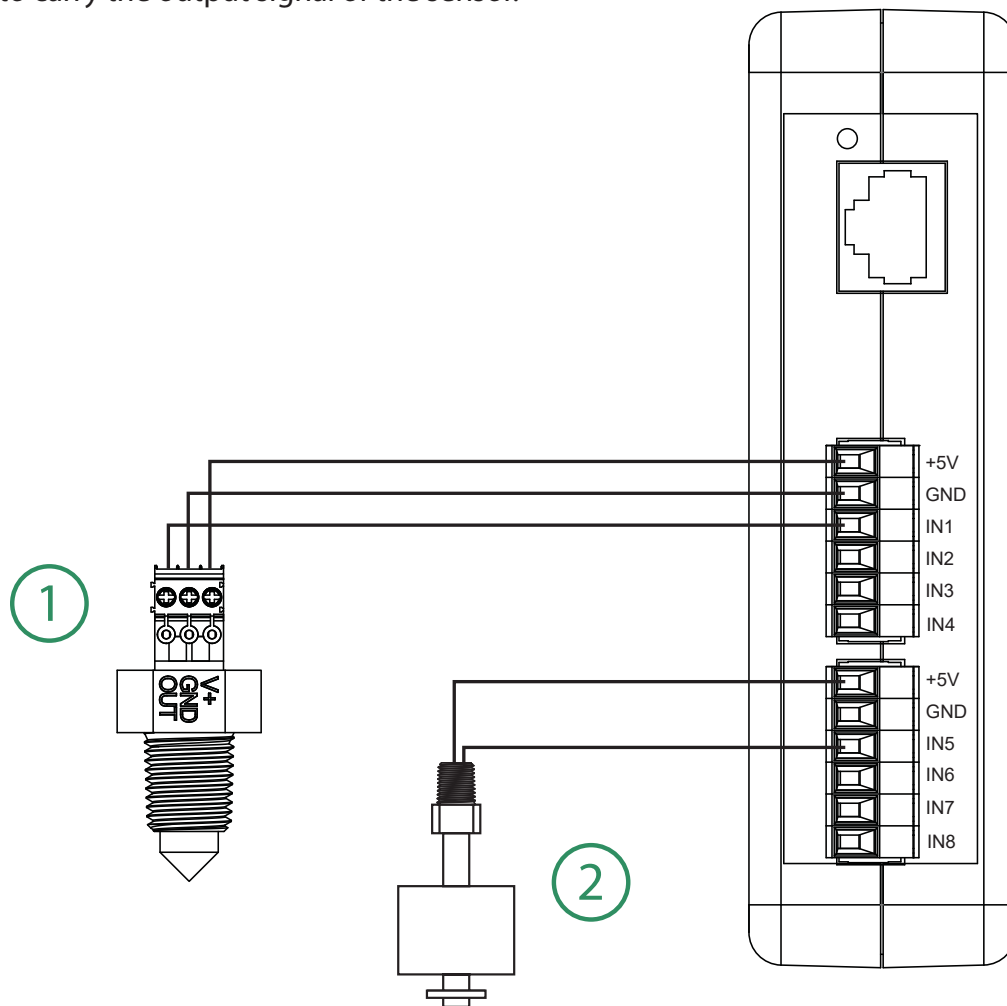

1. SXL Optical Liquid Sensor (powered sensor)

Requires three wires; V+, GND and signal output.

Connect the output of the sensor to the desired input terminal.

2. Float Switch (dry contact sensor)

Requires two wires; V+ and signal output. Connect the output of the sensor to the desired input terminal.

DIX8, DXIO Inputs (Analog Sensors)

Analog sensors offer a “variable” value such as a temperature, pressure, etc. The device’s analog inputs are 12 bit and offer 4096 steps of resolution (1.22mV or 0.005mA.) Each input has a default range in “Voltage” mode of 0-5Vdc, or if set with a jumper to a “Current” mode, a 0-20mA range.

Voltage Mode

Standard mode for 0-5Vdc analog sensors or discrete type sensors.

Current Mode

Mode for 0-20mA or 4-20mA type industrial analog sensors.

Note: Jumpers must be installed on the PCB for mA mode.

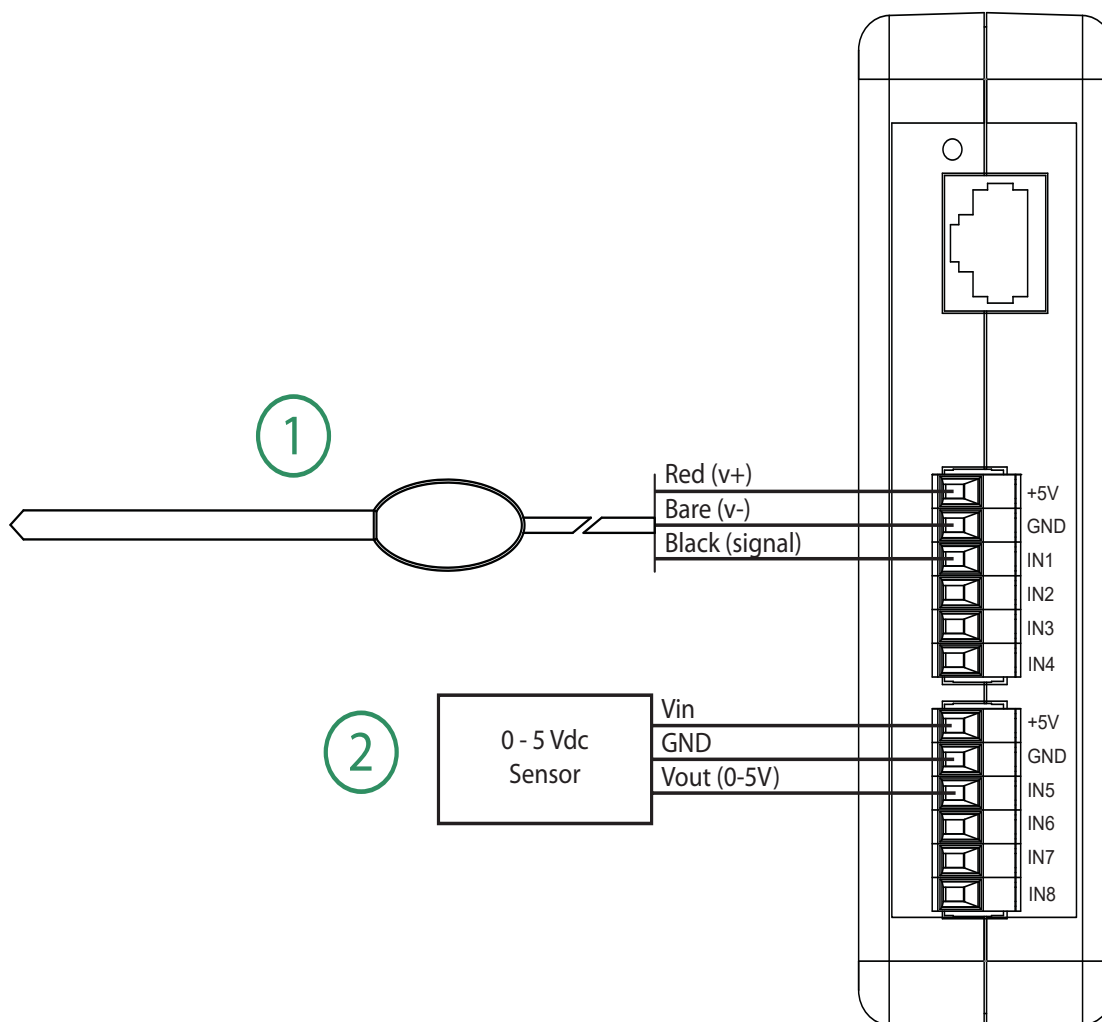

1. SXM-1 Soil Moisture Sensor (0-5V)

Requires three wires; V+, GND and signal output.

Connect the output of the sensor (black wire) to the desired input terminal.

2. 0-5V DC Sensor

Any standard three-wire 0-3V or 0-5V sensor can be integrated into a DXI8 module.

DXO8 Outputs (DC Voltage)

High current FET (transistor) outputs control DC loads. DXO8 and DXIO modules switch the voltage that is supplied to the unit at the Vin terminal block to the DC output terminals. Power is required at the Vin terminal block to supply the outputs with power. The default power supply is 24Vdc. Lower voltage may be supplied to the board (down to 9Vdc) depending on the requirements of the devices being driven.

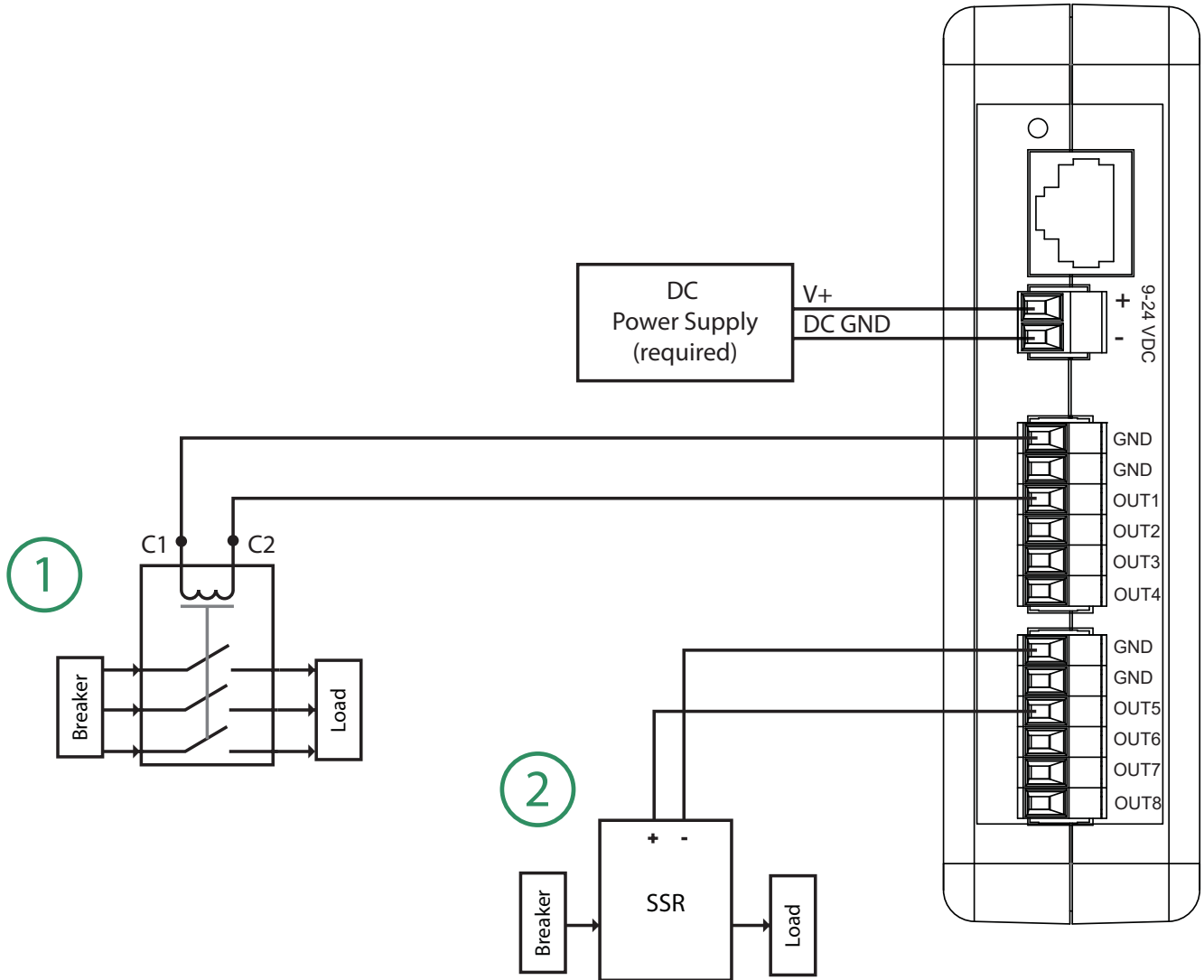

1. Electromechanical Relays & Contactors

DC powered relays and contactors with magnetic coils may be driven directly by the outputs. Each output is protected for flyback and surge, and is capable of up to 1A continuous current (1A max combined current.)

2. Solid State Relays

DC powered solid state relays (SSR's) may be driven by the DC output terminals.

DXO8 Outputs (PWM, AC Infinity Fans)

AC Infinity fans can be variable speed controlled with a PWM output signal from a DXO8 module. An analog scaling function or staged temperature control function can be used to vary the speed of the fans programmatically based on sensor conditions and scheduling.

Connection of the Infinity series fans can be accomplished per the diagram below and require a 1/4W 1K-Ohm termination resistor at the fan's PWM terminals. This resistor can be purchased locally or provided by Agrowtek (contact sales.) A 12Vdc power source is required on the module for the PWM signal.

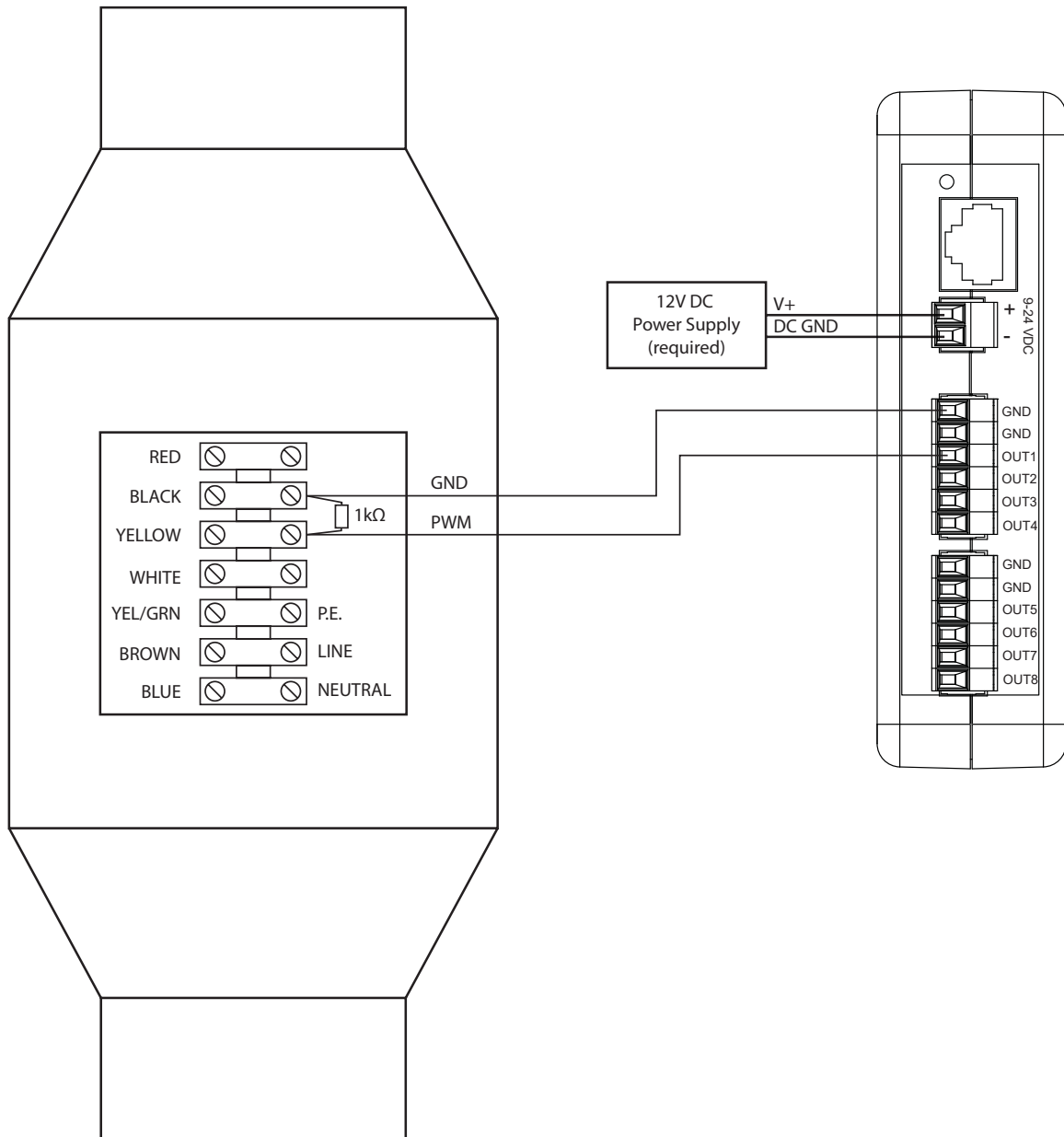

Connection details credit: Dwight Taylor.

DXR6 Outputs (Dry Contacts)

Dry-contact relays consist of a mechanical switch (contact) and an electro-magnet to turn-on (close) the switch contact. A spring opens the switch when the electromagnet is no longer powered. The contact switch operates the same way as a wall-switch, connecting two screw terminals together. Dry contacts are typically used for switching low-voltage AC control signals including HVAC units and irrigation solenoids.

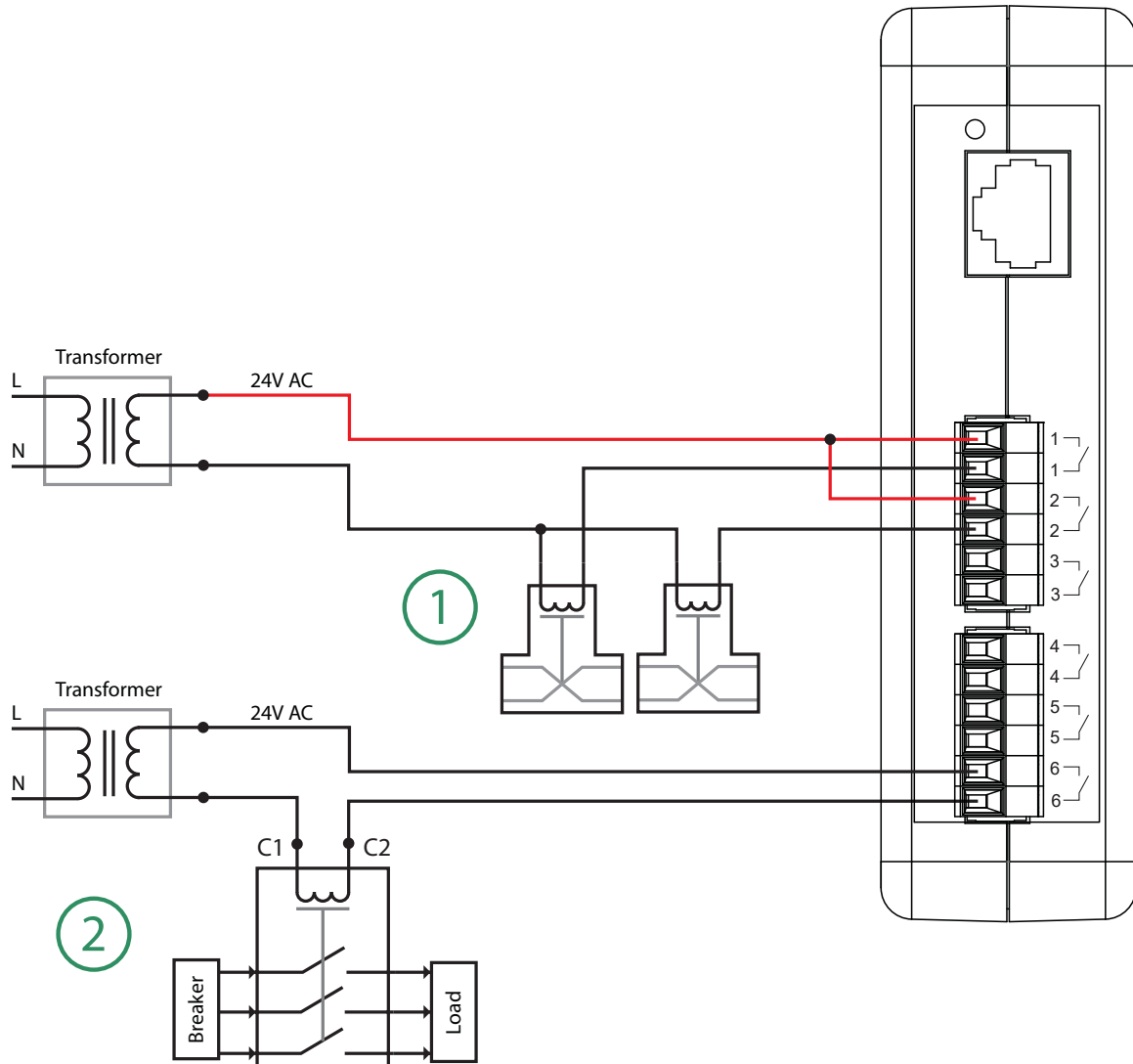

1. Irrigation Solenoid Valves

24VAC irrigation and gas valves can be controlled by switching power supplied by a step-down transformer. *24VAC is safer and more common than line-voltage for water/irrigation solenoids.*

2. A.C. Coil Relays & Contactors

Contactors and relays with 24VAC coils can be operated by controlling the power from a transformer to the magnet coil with a dry contact switch.

DXR6 Outputs (HVAC Control)

HVAC units typically supply 24VAC from a built-in control transformer located in the HVAC unit. The 24VAC supplied by the FCU is switch to the various control signal wires back to the FCU inputs activating the HVAC unit. Dry contacts are required to switch the AC control voltage in HVAC and commercial dehumidifier units.

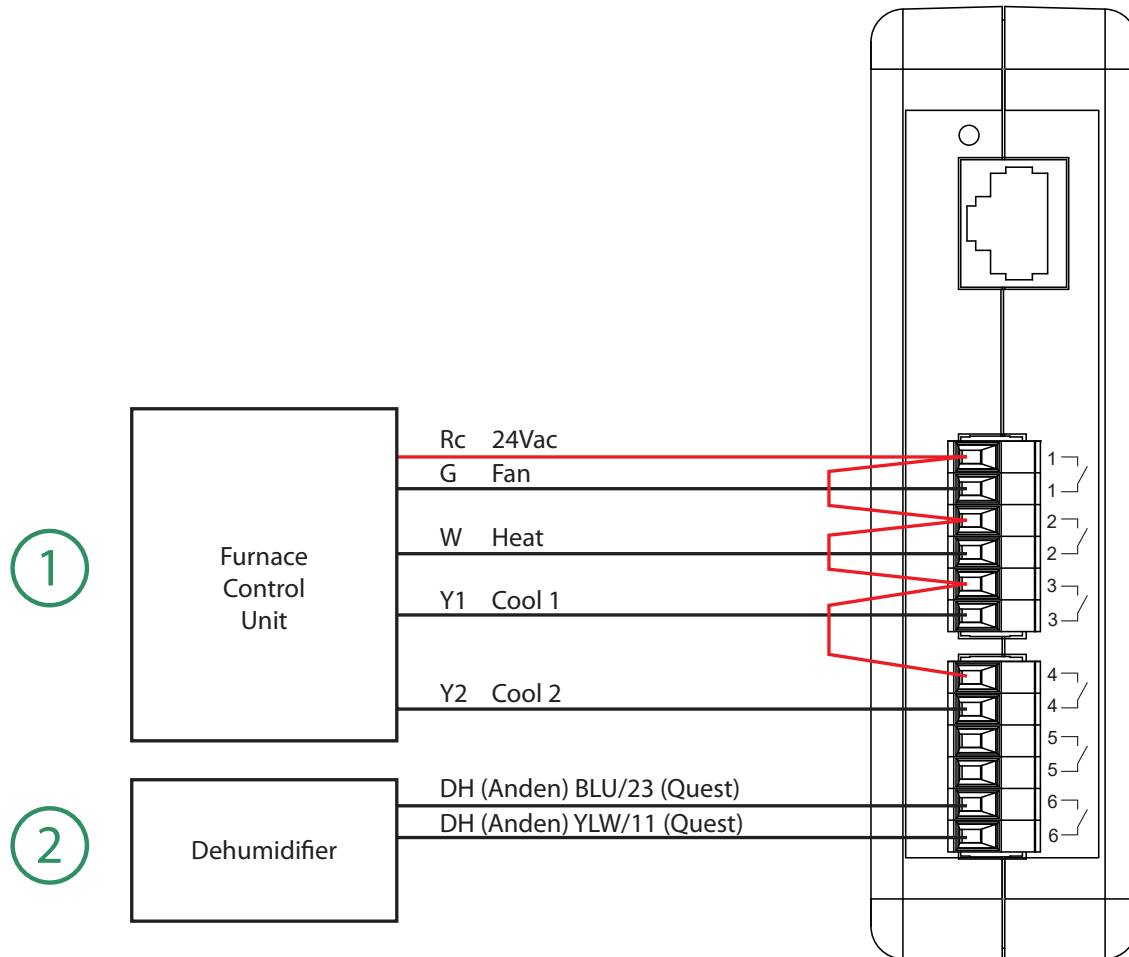

1. HVAC FCU

Typical example of connections to a RTU (roof top unit) HVAC system FCU (furnace control unit.)

2. Humidifiers & Dehumidifiers

Commercial humidifiers and dehumidifiers typically provide both an economical internal humidistat control and terminals for external humidistat control. Contact your equipment manufacturer or review your equipment installation manual for details on which connections to make for dry-contact external control.

DXR6 Outputs (Anden Dehumidifiers)

Anden dehumidifier units can be connected to a low-voltage dry-contact for external control. Multiple units can be daisy-chained together as shown in the diagram below.

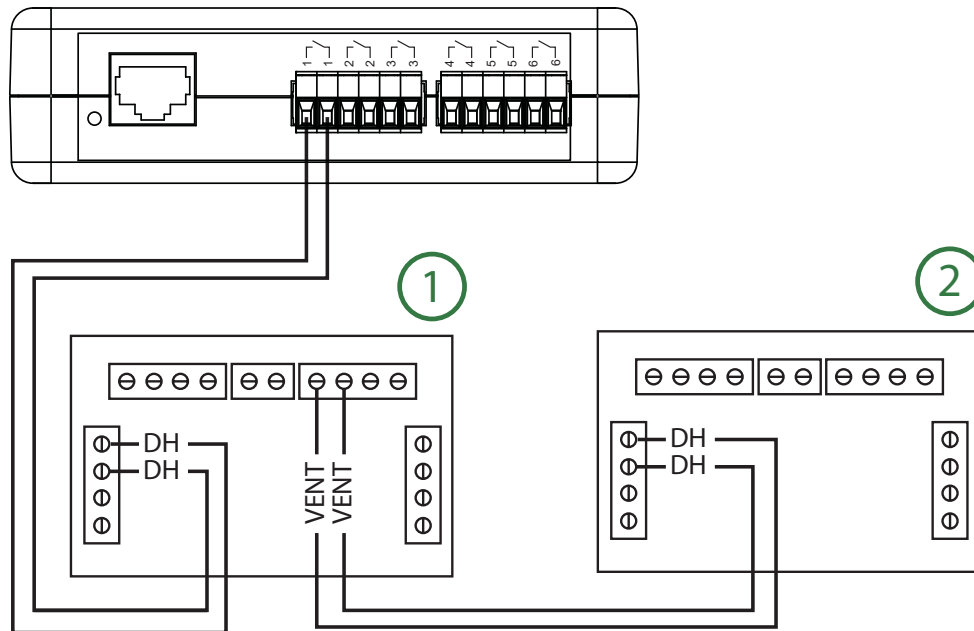

Connect the "DH" contacts of unit #2 to the "VENT" contacts of unit #1. Refer to Anden operation manual for additional setup instructions.

1. Dehumidifier Unit #1

Connect a dry-contact from the RD8i relay to the "DH" contacts on the first unit.

2. Dehumidifier Unit #2

Connect the "DH" contacts of unit #2 to the "VENT" contacts of unit #1.

Setup Procedure for External Control:

1. Press any button to activate the display and ensure the unit is set to "OFF."
2. Hold the "MODE" button for three (3) seconds to enter the installer setup menu.
3. "Remote" will be displayed on the screen.
4. Press the "MODE" button until "External Disabled" is shown on the screen.
5. Press "Up" or "Down" to set the display to "External Enabled."
6. Press "MODE" until "Done" is shown on the screen.
7. Press the "ON" button; "External" should be shown on the screen.

DXR6 Outputs (Quest Dehumidifiers)

Quest dehumidifier units can be connected to a low-voltage dry-contact for external control.

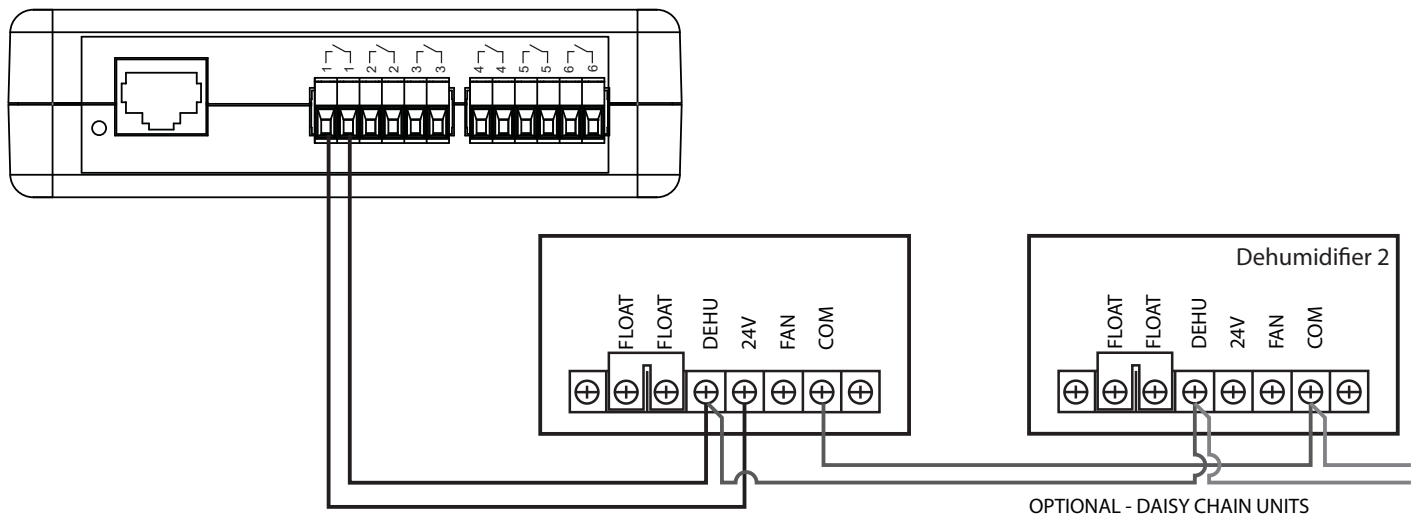

Optional

Models with separate fan control can use a second relay contact to operate only the fan for air circulation purposes if desired, otherwise, only the DEHU and 24V terminals are required on a single contact.

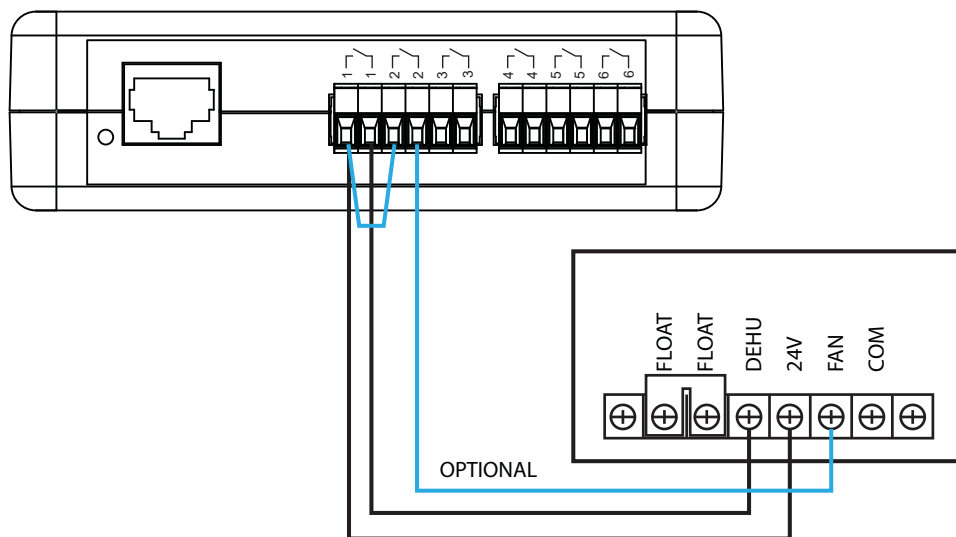

DXV4 Outputs, 0-10V (Analog Voltage)

Analog voltage outputs are designed for analog signal control primarily in light dimming and speed control applications. Power is required at the Vin terminal block to supply the outputs with power. The power supply must be in the range of 12-24Vdc. Up to 50 fixtures (typical) may be driven from a single output channel.

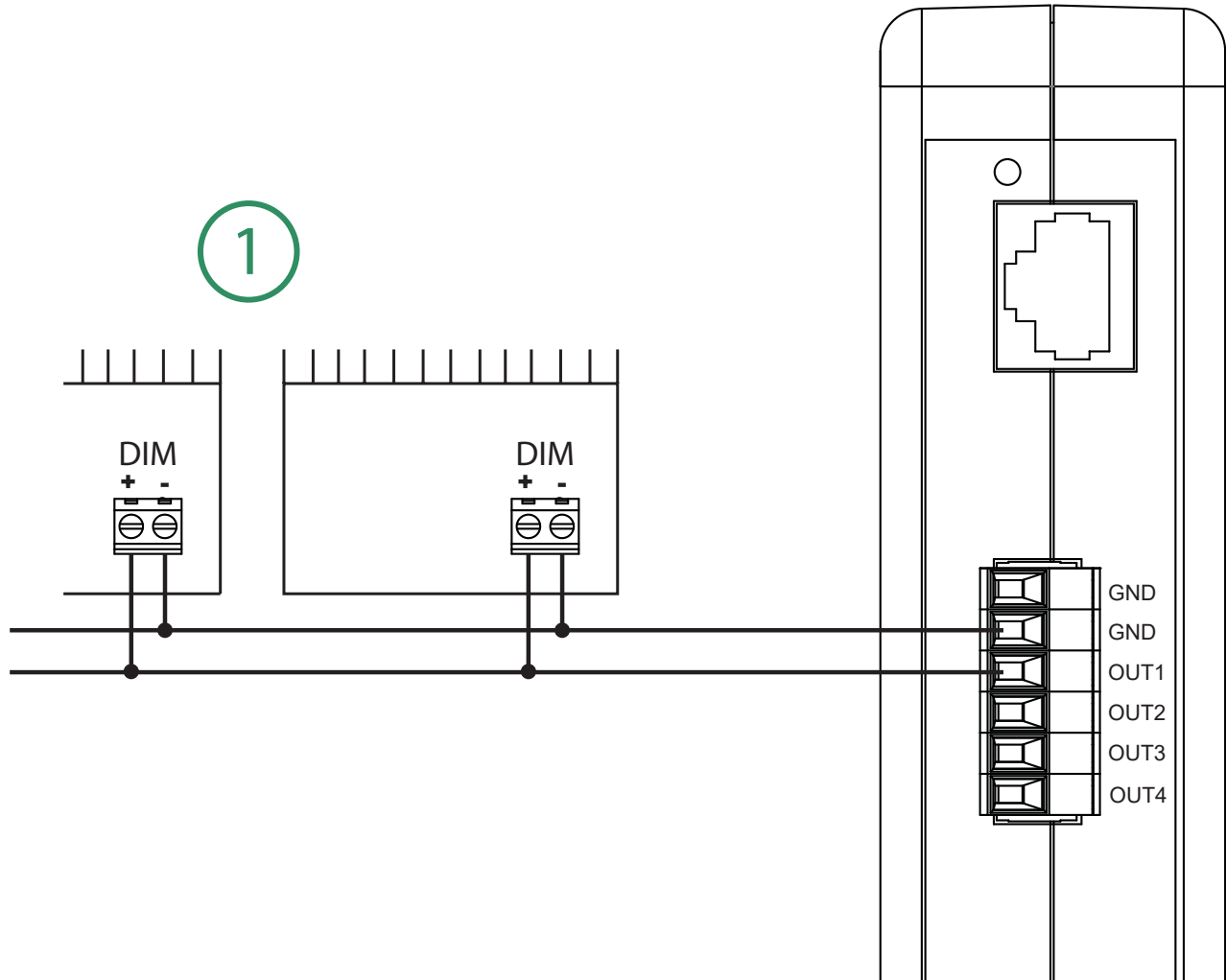

1. Dimmable Ballasts & VFD Motor Controllers

Ballasts and VFD controllers that accept a 0-10V signal may be controlled by one of four (4) analog voltage output channels. Each of the four channels may be set to 0-10Vdc independently. Internal feedback sensing manages voltage levels automatically accounting for unit loading.

DXV4 Outputs, RJ-45 (Gavita)

Gavita fixtures use a RJ-45 connector.

The connections from a standard RJ-45 connector to the DXV4 are detailed below.

Example shows connection to output channel #3.

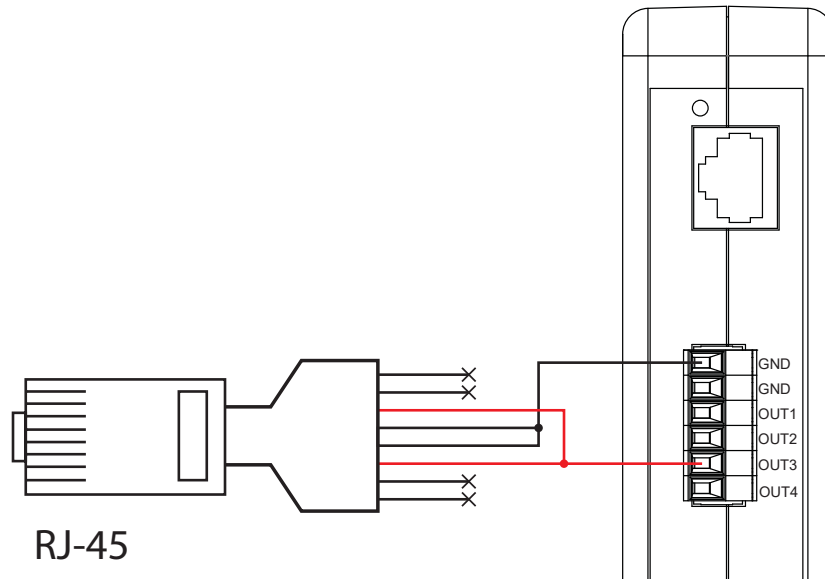

DXV4 Outputs 0-10V, RJ-12

Gavita, Grower's Choice, Luxx Lighting, and many other 0-10V dimmable fixtures use RJ-12 or similar style "phone" cord modular connectors.

The connections from a standard RJ-12 style connector to the DXV4 are detailed below.

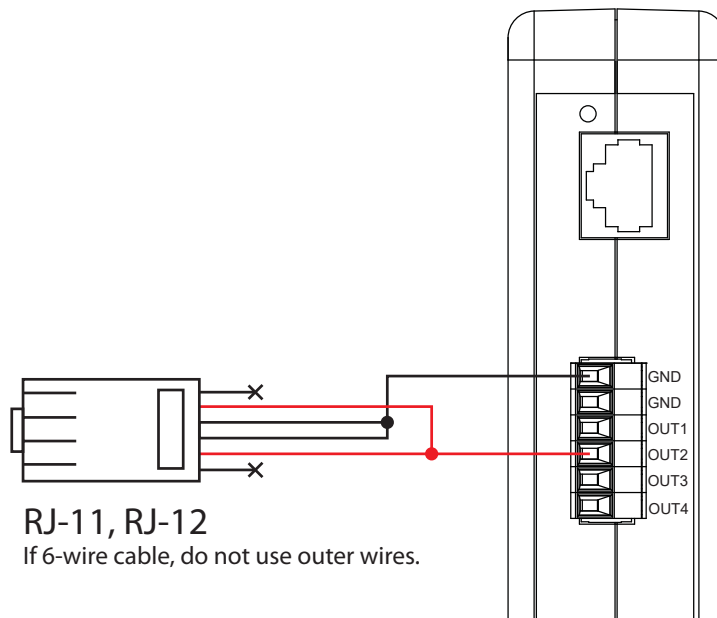

DXC4 Outputs, 4-20mA (Analog Current)

Analog current outputs are designed for control primarily in speed control and PLC applications.

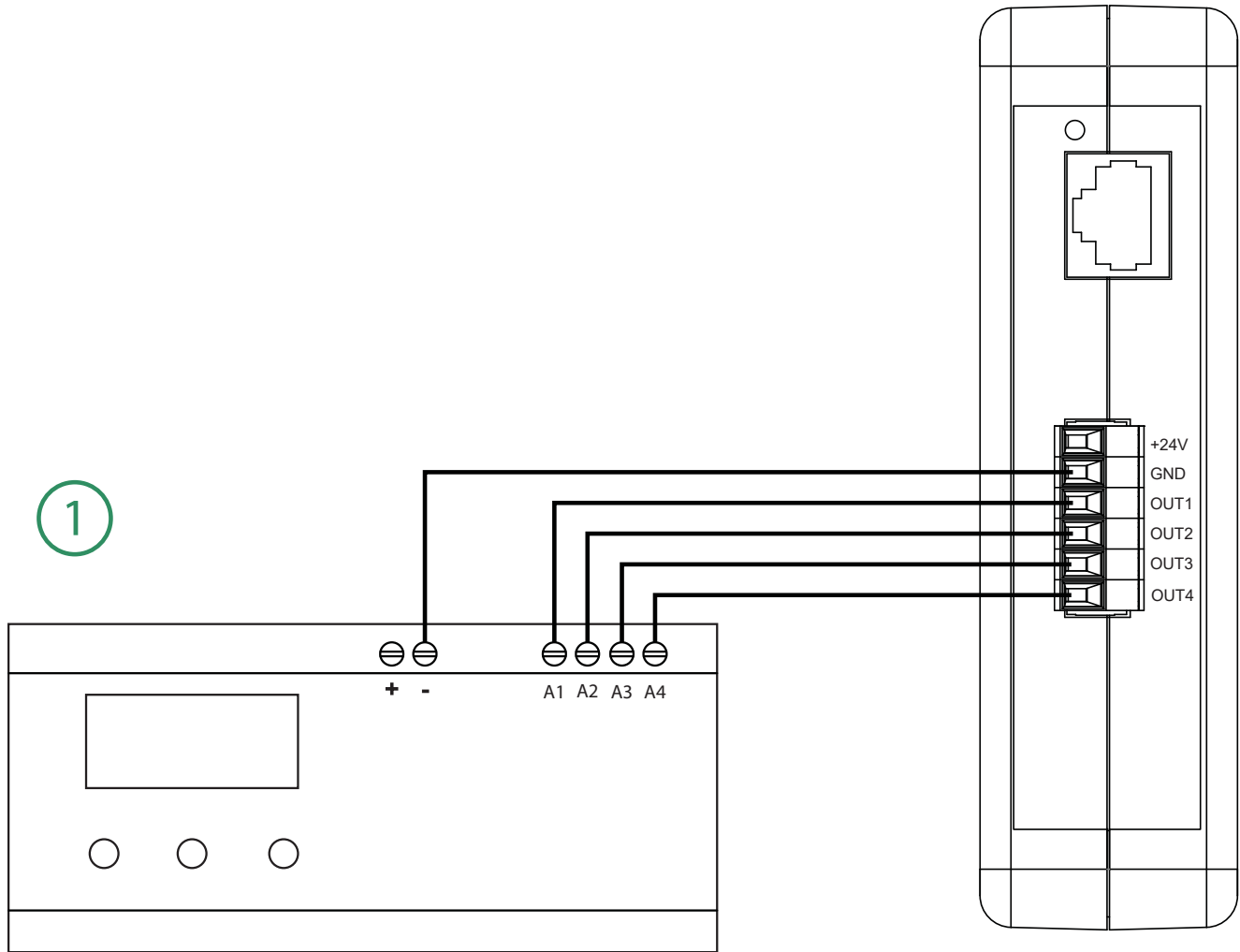

1. PLC or VFD

Equipment that is controlled with a 4-20mA signal should have the analog input connected to the desired analog output channel of the DXC4. The GND terminal should be connected to DC Ground (0V) on the PLC or VFD. Up to 500mA can be sourced from the +24V output terminal to operate small PLC's and devices.

Connection to GrowControl™ GCX

All GrowNET™ devices are connected using standard CAT5 Ethernet cable with RJ-45 connections.

Devices can be connected directly to the GrowNET™ ports on the bottom of the controller, or through HX8 GrowNET™ hubs. It is typical to simplify cabling by locating hubs centrally in hall ways and rooms allowing single runs from an 8-port device hub back to a central hub or back to the controller.

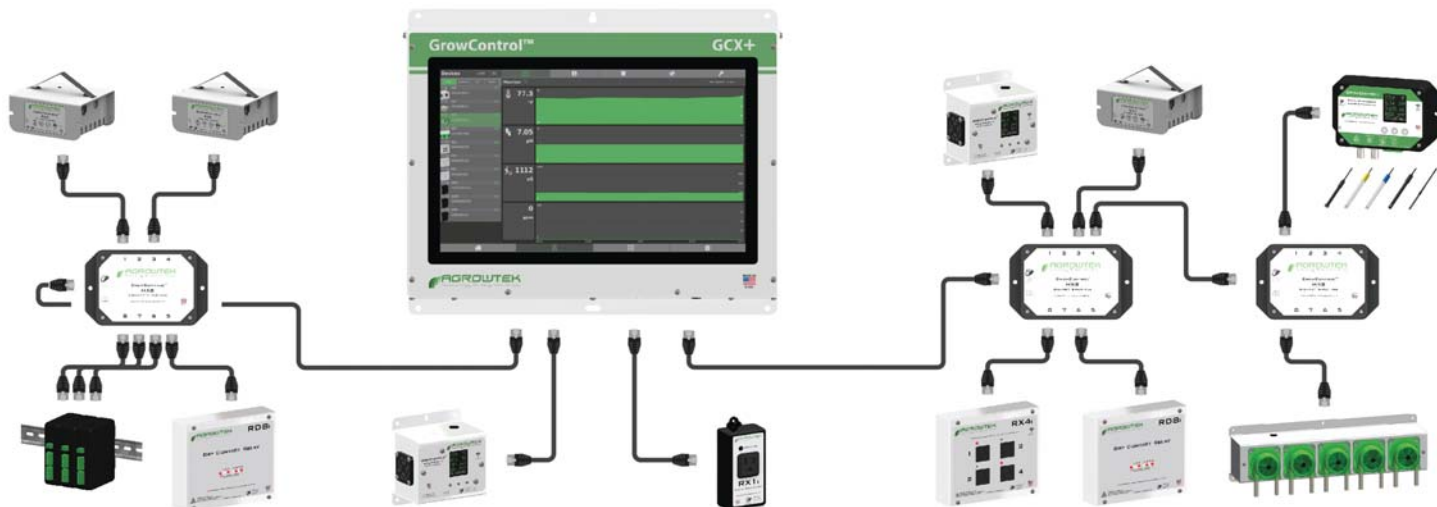

Refer to the GCX controller manual for details on adding the device to the system.

GrowNET™ Hubs

HX8 GrowNET™ hubs expand a single port into eight more ports. Hubs can be daisy-chained to form a network of up to 100 devices per GrowNET™ bus. Individually buffered port transceivers provide excellent signal integrity and extended communication strength and range.

Hubs provide up to 1A of power for operating sensors and most relays directly over the CAT5 cable. A DC jack on the hub provides 24Vdc power to the ports from the included wall power supply. A terminal block power option is also available.



Installation Notes

⚠ NOTICE

GrowNET™ ports use standard RJ-45 connections but are NOT compatible the Ethernet network equipment. *Do not connect GrowNET™ ports to Ethernet ports or network switch gear.*

⚠ DIELECTRIC GREASE

Dielectric grease is recommended on RJ-45 GrowNET™ connections when used in humid environments. Place a small amount of grease onto the RJ-45 plug contacts before inserting into the GrowNET™ port. *Non-conductive grease is designed to prevent corrosion from moisture in electrical connectors.*

- Loctite LB 8423
- Dupont Molykote 4/5
- CRC 05105 Di-Electric Grease
- Super Lube 91016 Silicone Dielectric Grease
- Other Silicone or Lithium based insulating grease

MODBUS RTU

RS-485

Use the LX2 ModLINK to connect MODBUS devices to the GrowNET™ port.

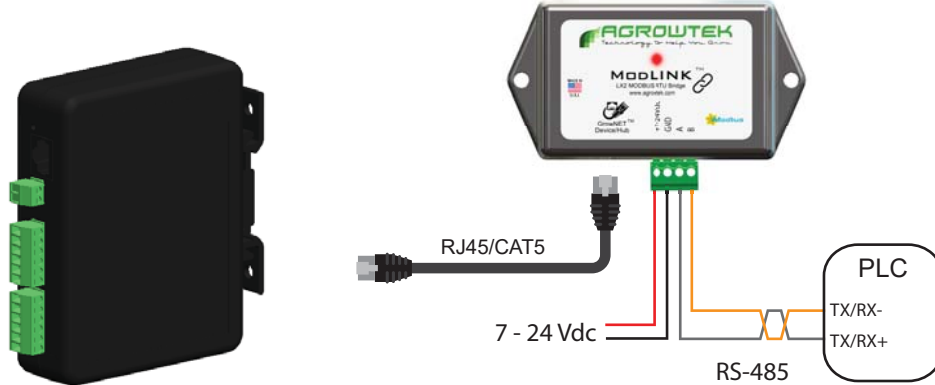

3.3/5Vdc Serial Bus Compatible.

Include required bus terminating resistors per EIA standard.

Serial Speed & Format

The default serial data format for the LX2 ModLINK interface is: **19,200 baud, 8-N-1.**

Alternate speeds and formats between 9,600 - 115,200 baud may be configured with the free AgrowLINK PC utility using a LX1 USB AgrowLINK and the cross-over adapter supplied with the LX2 ModLINK.

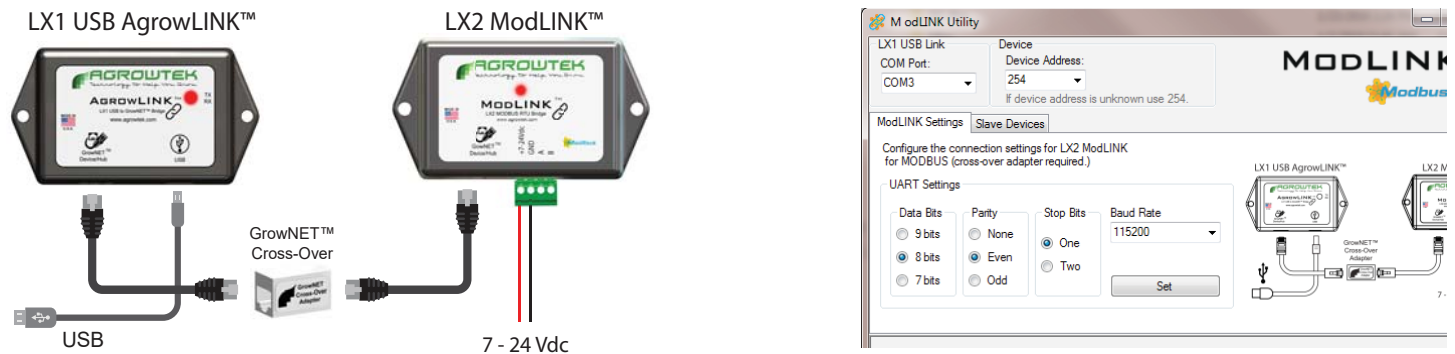

Supported Commands

- 0x01 Read Coils
- 0x03 Read Multiple Registers
- 0x05 Write Single Coil
- 0x06 Write Single Register
- 0x15 Write Multiple Coils

A request to use a function that is not available will return an illegal function error (0x01).

Register Types

Data registers are 16 bits wide with addresses using the standard MODICON protocol. Floating point values use the standard IEEE 32-bit format occupying two contiguous 16 bit registers. ASCII values are stored with two characters (bytes) per register in hexadecimal format. Coil registers are single bit values which control and indicate the status of a relay; 1 = on, 0 = off.

MODBUS Holding Registers

Parameter	Description	Range	Type	Access	Address
Address	Device Slave Address	1 - 247	8 bit	R/W	40001
Serial#	Device Serial Number	ASCII	8 char	R	40004
DOM	Date of Manufacture	ASCII	8 char	R	40008
HW Version	Hardware Version	ASCII	8 char	R	40012
FW Version	Firmware Version	ASCII	8 char	R	40016
Device Model	Product Model Number	ASCII	8 char	R	40020
Analog Input Value, Integer	Input 1	Signed Int	16 bit, signed	R	40101
	Input 2				40102
	Input 3				40103
	Input 4				40104
	Input 5				40105
	Input 6				40106
	Input 7				40107
	Input 8				40108
Analog Input Value, Floating Point	Input 1	Floating Point	32 bit, float	R	40201
	Input 2				40203
	Input 3				40205
	Input 4				40207
	Input 5				40209
	Input 6				40211
	Input 7				40213
	Input 8				40215
PWM Output (Duty Cycle %) 0-10V Output (0-10,000mV)	Output 1	0-100 or 0-10,000	16 bit, signed	R/W	40301
	Output 2				40302
	Output 3				40303
	Output 4				40304
	Output 5				40305
	Output 6				40306
Timeout (seconds)	Turn off outputs if no communication	0 - 32767	16 bit, unsigned	R/W	41001
Output Closure Count, Discrete	Output 1	Unsigned Int	32 bit, unsigned	R	49001
	Output 2				49003
	Output 3				49005
	Output 4				49007
	Output 5				49009
	Output 6				49011
	Output 7				49013
	Output 8				49015

MODBUS Coil Registers

Parameter	Access	Address
Relay 1	R/W	1
Relay 2	R/W	2
Relay 3	R/W	3
Relay 4	R/W	4
Relay 5	R/W	5
Relay 6	R/W	6
Relay 7	R/W	7
Relay 8	R/W	8

A request to read or write coils/registers that are not available will return an illegal address error (0x02.)

Technical Information

Troubleshooting

Outputs are not activating, LED does not flash

The status LED will flash three times on power-up and each time data is transmitted. Ensure the input power has 9-24Vdc and are correctly wired for polarity.

Maintenance & Service

Exterior Cleaning

Exterior may be wiped with a damp cloth with mild dish detergent, then wiped dry. Disconnect power before cleaning the enclosure to prevent electrical shock.

Storage and Disposal

Storage

Store equipment in a clean, dry environment with ambient temperature between 10-50°C.

Disposal

This industrial control equipment may contain traces of lead or other metals and environmental contaminants and must not be discarded as unsorted municipal waste, but must be collected separately for the purpose of treatment, recovery and environmentally sound disposal. Wash hands after handling internal components or PCB's.

Warranty

Agrowtek Inc. warrants that all manufactured products are, to the best of its knowledge, free of defective material and workmanship and warrants this product for one (1) year from the date of purchase. This warranty is extended to the original purchaser from the date of receipt. This warranty does not cover damages from abuse, accidental breakage, or units that have been modified, altered, or installed in a manner other than that which is specified in the installation instructions. This warranty is applicable only to products that have been properly stored, installed, and maintained per the installation and operation manual and used for their intended purpose. This limited warranty does not cover products installed in or operated under unusual conditions or environments including, but not limited to, excessive humidity or extreme temperature conditions outside of the specified limits. Agrowtek Inc. must be contacted prior to return shipment for a return authorization. No returns will be accepted without a return authorization. Returns not purchased directly from Agrowtek Inc. must include proof of purchase date otherwise purchase date is considered date of manufacture. The products which have been claimed and comply with the aforementioned restrictions shall be replaced or repaired at the sole discretion of the Agrowtek Inc. at no charge. This warranty is provided in lieu of all other warranty provisions, express or implied. It is including but not limited to any implied warranty of fitness or merchantability for a particular purpose and is limited to the Warranty Period. In no event or circumstance shall Agrowtek Inc. be liable to any third party or the claimant for damages in excess of the price paid for the product, or for any loss of use, inconvenience, commercial loss, loss of time, lost profits or savings or any other incidental, consequential or special damages arising out of the use of, or inability to use, the product. This disclaimer is made to the fullest extent allowed by law or regulation and is specifically made to specify that the liability of Agrowtek Inc. under this limited warranty, or any claimed extension thereof, shall be to replace or repair the Product or refund the price paid for the Product.